

IRD series
8" LED Inset Lights

- RC/IN Runway Centre Line
- TZ/IN Touchdown Zone
- FI/IN Rapid Exit Taxiway Indicator
- THL/IN Take-off and Hold
- RE/IN Runway End Stopway



FEATURES

- Low protrusion of 6.3mm above ground level
- Adaptable to all kinds of CCRs and ILCMS systems
- PWM digital regulation providing excellent consistency of chromaticity
- Integrated optical module with high light efficacy and good consistency
- Aluminum alloy forged top cover with hardened surface and corrosion resistance treatment
- Built-in surge protection
- Specially designed fail open system suitable for strong magnetism, vibration and other environments

- | | |
|-----------------------------|--------------------------|
| ICAO • Annex 14 Volume I | FAA • AC 150/5345-46 |
| EASA • CS-ADR-DSN | • EB No. 67 |
| CAAC • AC-137-CA-2015-01-R1 | IEC • TS 61827 |
| • AC-137-CA-2015-03-R1 | AENA • DIN/DSEYN/PPT/010 |
| | • DIN/DSEYN/PPT/013 |

TECHNICAL DATA

MECHANICAL

Mounting • 2 x M10 bolts Static Load Resistance • $\geq 20t$ Dynamic Load Resistance • 40J Net Weight • 3.5kg
 Gross Weight • 3.7kg Packing Dimensions • 253mm (L) x 223mm (W) x 107mm (H)

ENVIRONMENTAL

Operating Temperature • - 55°C~+85°C Storage Temperature • - 55°C~+85°C Protection Class • IP68 Humidity • 0~100%

ELECTRICAL

Connection • FAA L-823	Rated Input Current • 6.6A	Power Factor • >0.95
Emission • IEC 61000-6-4	Immunity • IEC 61000-6-2	Service Life • LED useful lamp life > 80000h
Runway Centre Line -White/White • 26.5VA (1P) • 11/11VA (2P)		Runway Centre Line -White/Red • 26.5VA (1P) • 11/8VA (2P)
Runway Centre Line-White • 20VA	Runway Centre Line-Red • 16.5VA	Rapid Exit Taxiway Indicator • 20.5VA
Runway End • 18.5VA	Touchdown Zone • 20.5VA	Take-off and Hold • 18.5VA

COMPONENTS

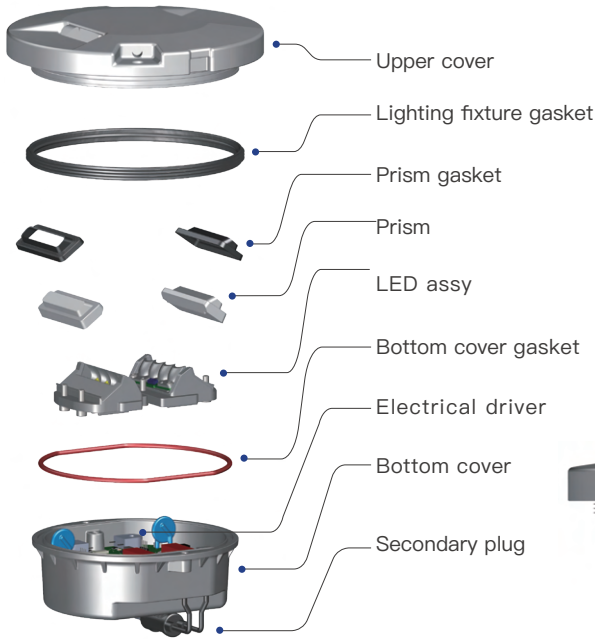

DIMENSIONS

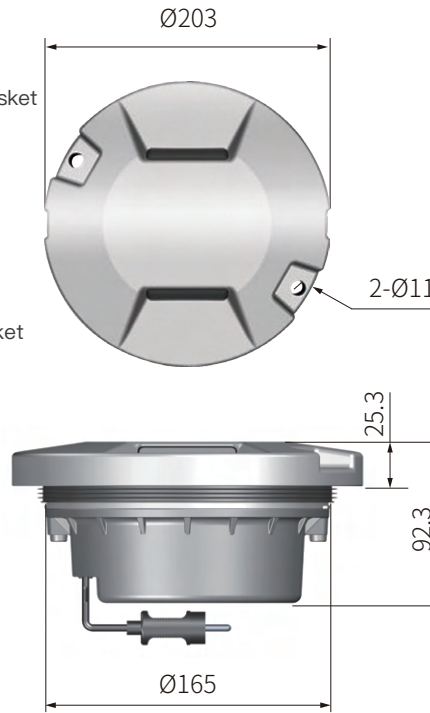

ACCESSORIES

- ◎ 8 inches shallow base assy (bottom entry/side entry)
- ◎ 12 inches shallow base assy (bottom entry/side entry)
- ◎ 12 inches deep base assy
- ◎ 12-8 inches adapter ring assy
- ◎ L-823 receptacle
- ◎ 8 inches light fixture handle

PHOTOMETRICS

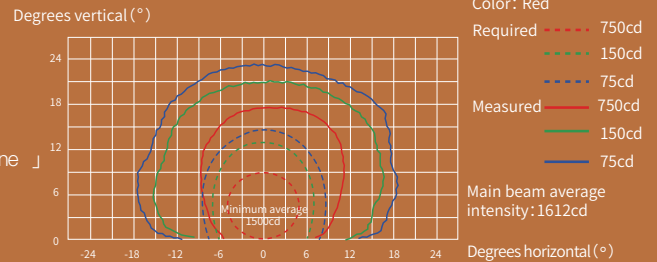
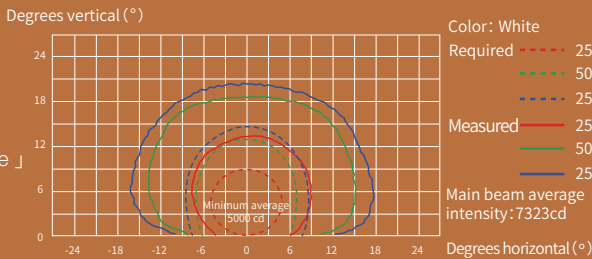

Airfield Lighting Systems (UK) Limited
Aviation House, Russell Gardens,
Wickford, Essex, SS11 8BF UK

Tel: +44 1702 547562
Email: sales@alsukltd.co.uk Website:
www.alsukltd.co.uk

ORDERING CODES

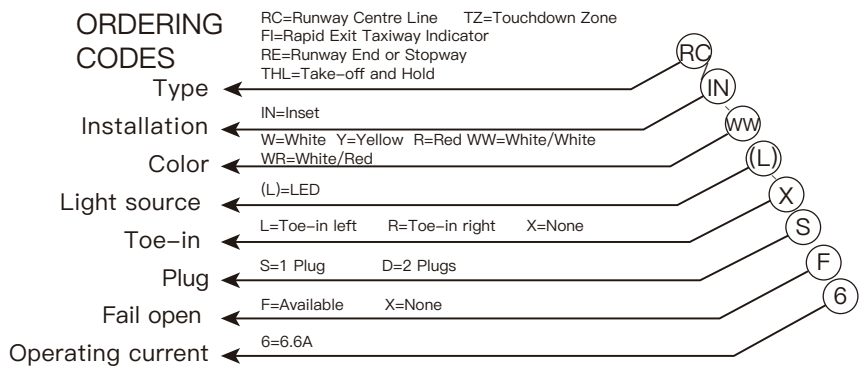

* Accessories should be ordered separately